

Cone Crusher



SHANGHAI KINGLINK INDUSTRY CO.,LTD



Strong, cost-effective, high capacity...

A cost-effective solution for medium to high tonnage aggregate and mining operations, our Cone crusher has a maximum throughput of almost 7,00TPH in secondary applications, and can handle feed size to 11 inches (280mm). KL cone crushers are backed by professional, responsive service of combined crusher experience.

- The main body of the cone crusher is box shaped cast steel structure, whose heavy loading areas are reinforced by hard steel.
- KL series high efficiency cone crusher is designed with the help of modern CAD technology. All series models have gone through the FEM technology analysis, which ensures all stress levels inside within appropriate range and guarantees the high strength structure and stable performance of WL series high efficiency cone crusher.
- KL High efficiency compound cone crusher adopts tapered roller bearing to replace the old style horizontal shaft copper sleeve at both ends of the horizontal drive shaft and thus largely improves its rotation speed. Dust proof ring is assembled between the mantle cone and the seat liner. The maze O-ring is full of lubrication oil. The dust proof ring is supported by the spring in the seat liner so as to prevent dust from entering. The machine adopts electric automatic lubrication system that connects the main motor. If the pressure is insufficient or the temperature is too high, the main motor stops immediately to prevent the main engine from damage.
- The fine crushing chamber shape increases the effective crushing surface. The machine has the capacity to process larger feed size, increases 1/3 production capacity comparing with other cone crushers and can produce fine particles and cubic products. The mantle core and the crushing chamber are processed by digital control CNC machine, which makes the replacement of wearing plates quick and easy, eliminates the need to fill epoxide resin and improves the operational efficiency.
- Hydraulic pressure cylinder device can achieves iron release and quick chamber clearing by its some hydraulic cylinders. The machine is installed with hydraulic pressure adjustment device so as to quickly adjust the discharge gap and clear the crushing chamber and therefore reduce the time of machine halt.



High Strength And Firm Frame

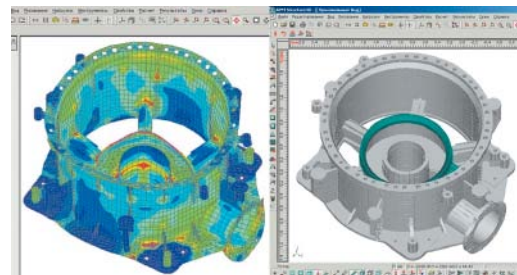

Finite Element Design

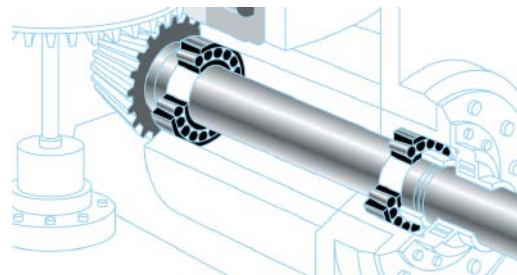

Tapered Roller Bearing

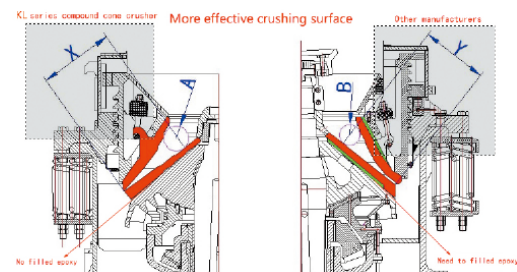

No Filled Epoxy



Hydraulic Adjustment

CLEARANCE DIMENSIONS

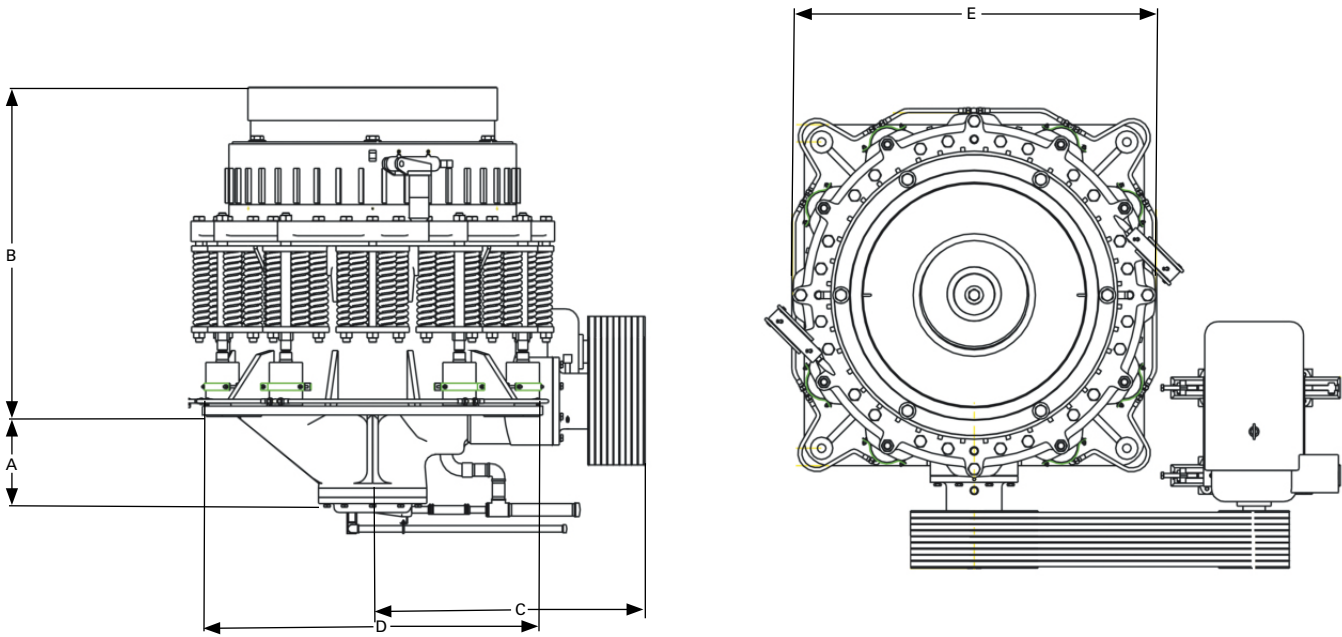

Section	Model	KL600		KL1000		KL1160		KL1300		KL1380		KL1500		KL1680	
		(in)	(mm)	(in)	(mm)	(in)	(mm)	(in)	(mm)	(in)	(mm)	(in)	(mm)	(in)	(mm)
A	Base to Bottom of Oil Piping	13.1	335	13.4	340	18.5	470	21.8	554	24.2	615	24.6	625	29.3	745
B	Height from Base to Top of Feed Hopper	45.6	1159	65	1650	67.5	1715	81.5	2070	85.3	2168	92.9	2361	111.6	2835
C	Clearance Required to Remove Countershaft Assembly	40.3	1024	53.2	1351	57.9	1471	27	1685	68.1	1730	77.2	1961	80	2034
D	Main Frame Flange to Countershaft Housing Face	46.4	1180	60.2	1530	69.3	1760	81.5	2070	86.6	2200	96.4	2450	112.6	2860
E	Adjustment Ring Max Diameter	48.4	1230	81	2057	93.4	2372	103.5	2630	93.8	2384	103.1	2620	118.5	3010

All dimensions are for reference only and are not to be used for construction.

WEIGHT OF MAJOR SUB-ASSEMBLIES

Parts	Model	Approx. Weights Of Main Partas Assembly(TONS)					
		KL600	KL1000	KL1160	KL1300	KL1380	KL1500
Lower Frame+Top Frame		2.25	5.3	7.3	11	13	17.6
Main Frame-Top Frame		0.85	2.2	3.2	4.4	5.5	7.9
Eccentric Seat		0.25	0.5	0.65	1.1	1.25	2.1
Main Shaft		0.48	1.3	2.1	3.1	3.75	5.9
Counter-Shaft		0.34	0.6	0.75	1.0	1.0	1.7

All parameters are for reference only.

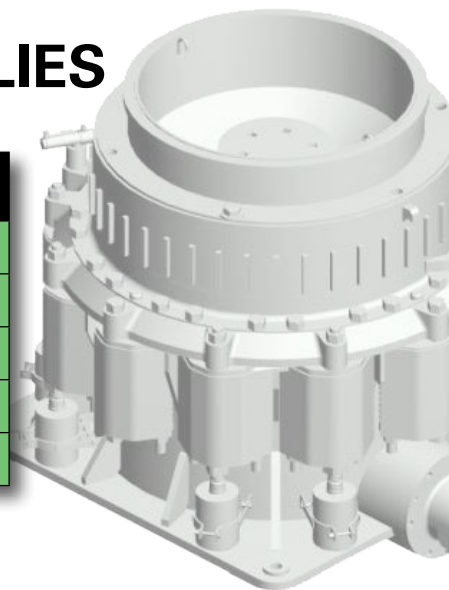

4 PROCESSING EQUIPMENT





6 » FEATURES

TOP CELL LINER

- Acts as wear part to protect top cell



TOP FRAME LOWER FRAME

- Heavy duty design construction co2 shield arc welded process and fully stress relieved heat treatment after welding.



BEVELED GEARS

- Forged bevel gears used as power transfer mechanism to reduce noises and enhance strength.

HYDRAULIC CYLINDERS

- Used to relieve materials in crushing chamber when the crusher stops during operation.

INNER BUSH & OUTER BUSH

- Made of high lead copper alloy to improve the lubrication effectiveness due to the existence of lead.



MAIN SHAFT

- Made of SCM4 and homogenised to ensure high strength

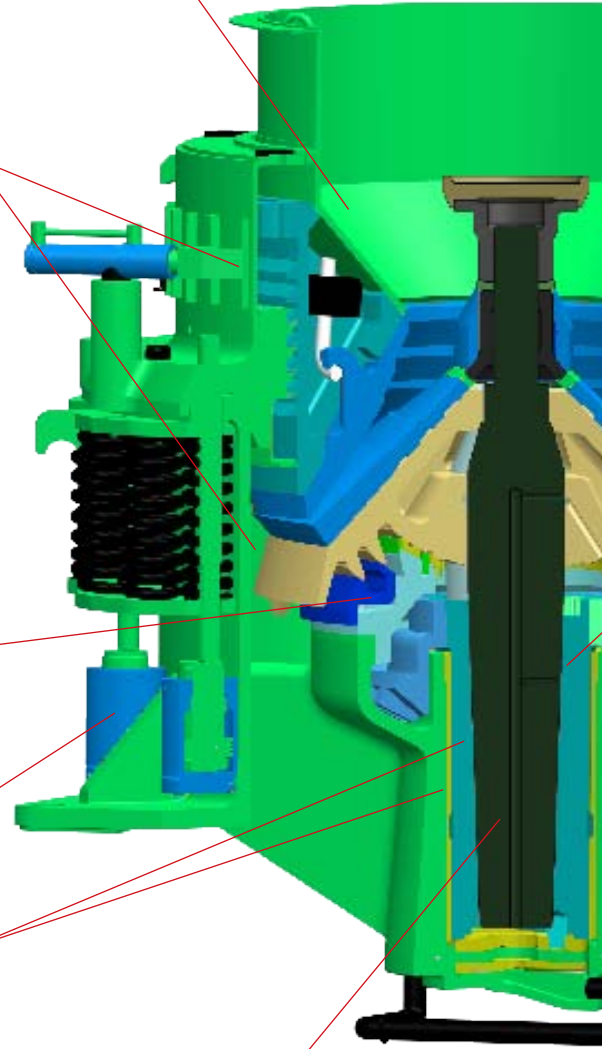

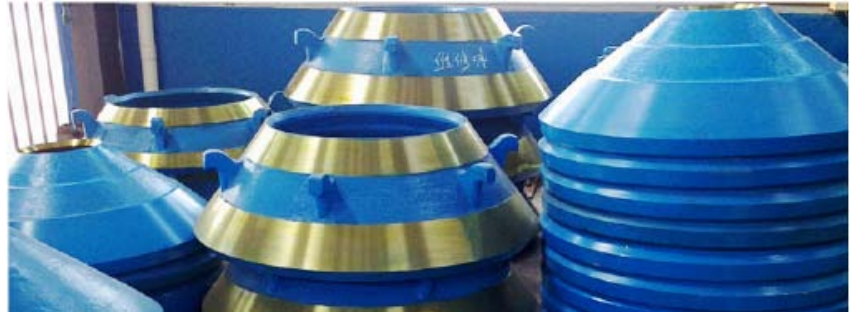

MANTLE AND CONCAVE

- Mantle and concave are made of high manganese steel

ECCENTRIC

SPRINGS

- Providing protection against damage due to tramp orin or other uncrushable materials that enter into the crushing chamber.



COUNTER BEARINGS

- A counter shaft is supported by two tapered roller bearings with oil pool system to absorb the axial force caused by bevel gear sets

SHAFT HOUSING



LUBRICATION SYSTEM

- The lubrication equipment installed outside of the machine provides stable hydraulic pressure and lubricates the exact position where lubrication is needed

8 » CAPACITY CHART

Model	Cavity	Cone Diameter		Max Feed Size		Min Discharge Size		Speed	Main Motor Power
		inch	mm	inch	mm	inch	mm	RPM	kW
KLC600	Coarse	24"	600	3 3/4"	95	3/8"	10	630	37-55
KLF600	Fine	24"	600	3"	72	1/4"	6	630	37-55
KLC1000	Coarse	40"	1016	6 5/16"	160	1/2"	13	630	90-110
KLM1000	Medium	40"	1016	4 1/2"	115	3/8"	10	630	90-110
KLF1000	Fine	40"	1016	3 3/16"	80	5/16"	8	630	90-110
KLC1160	Coarse	45"	1143	7 1/8"	180	1/2"	13	630	110-132
KLM1160	Medium	45"	1143	5 1/8"	130	3/8"	10	630	110-132
KLF1160	Fine	45"	1143	3 1/2"	90	3/8"	10	630	110-132
KLC1300	Coarse	51"	1296	7 7/8"	200	5/8"	16	610	132-160
KLM1300	Medium	51"	1296	6"	150	1/2"	13	610	132-160
KLF1300	Fine	51"	1296	4"	102	3/8"	10	610	132-160
KLC1380	Coarse	54"	1372	8 1/2"	215	3/4"	19	610	185-220
KLM1380	Medium	54"	1372	6 5/16"	160	5/8"	16	610	185-220
KLF1380	Fine	54"	1372	4 1/2"	115	1/2"	13	610	185-220
KLC1500	Coarse	60"	1524	9 1/4"	235	7/8"	22	560	220-250
KLM1500	Medium	60"	1524	7"	175	3/4"	19	560	220-250
KLF1500	Fine	60"	1524	5 1/8"	130	1/2"	13	560	220-250
KLC1680	Coarse	66"	1676	10 1/2"	267	7/8"	22	560	250-300
KLM1680	Medium	66"	1676	8"	203	5/8"	16	560	250-300
KLF1680	Fine	66"	1676	5 1/2"	140	1/2"	13	560	250-300

Note:1)Above parameters based on rock density 1.6t/m³,compressive strength <150MPa,moisture content<20%.

2)Processing capacity influence by uniform feeding,grain size,hardness,rock types,feeding speed etc.

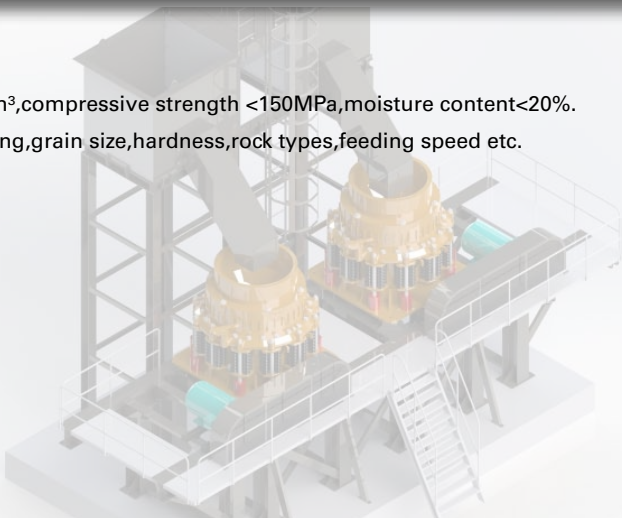

Weight										
T	1/4" 6	3/8" 10	1/2" 13	5/8" 16	3/4" 19	7/8" 22	1" 25	1 1/2" 38	2" 51	2 1/2" 64
5.3		20	25	30	35	45	50	76		
5.3	18	20	25	30	35	40	45	60		
10.8			80	100	135	150	175	235		
10.8		65	75	90	120	135	150			
10.8	52	62	72	78	115					
16			115	135	150	180	200	260		
16		100	110	120	135	165	175			
16		80	105	110	140					
23				150	180	200	230	310	390	
23			115	140	160	190	210			
23		90	115	145	160					
27					200	220	260	350	440	
27				155	180	200	220			
27			150	190	210	230				
37.8						265	310	420	525	580
37.8					215	240	265	320		
37.8			180	210	235	255	275			
44.3						330	390	525	655	725
44.3				210	250	280	300			
44.3			180	220	260	335				



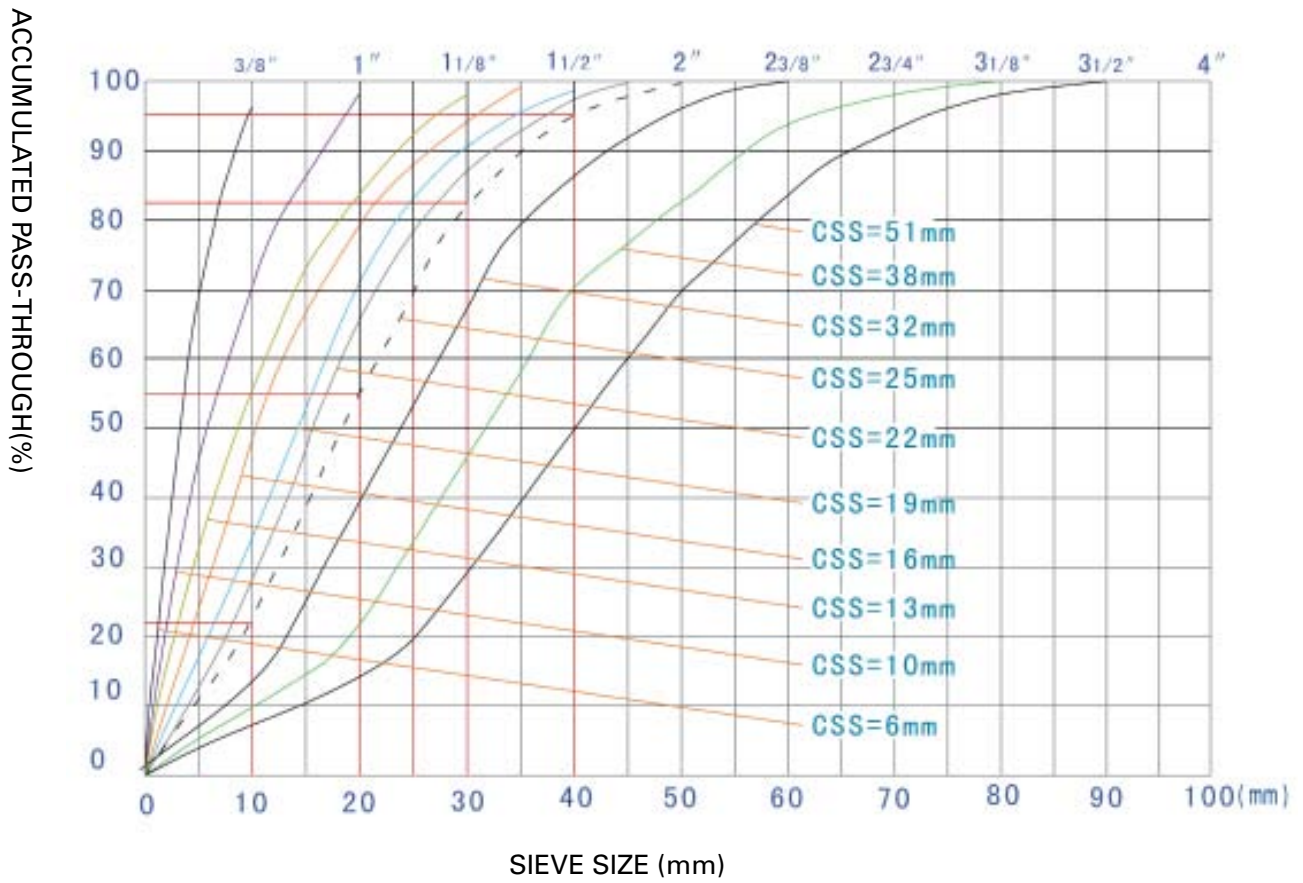

Feed and product curves are relative and based on actual test data. If the feed varies from that show, products and capacities will also vary. Consult Kinglink for more information.



- Strive for a 2 hour response time from service agents.
- Commitment to getting crusher operating as expected.
- Investment in smart, hard-working and industry experienced service team.
- Direct line to technical support group, 24-hours a day at [+86-15601968455](tel:+86-15601968455)



QUICK DELIVERED PARTS

- Large inventory increases parts availability and reduces wait time.
- Centrally-located warehouse for quick deliveries.
- Critical third party parts are inspected for integrity.
- High quality factory parts are backed by fitup assurance.
- 1-Year Parts Warranty:
 - ↳ Covers new parts against defects in material or workmanship.
 - ↳ Excludes normal wear and tear.



NOTE: SPECIFICATIONS ARE SUBJECT TO CHANGE WITHOUT NOTICE

Because Kinglink may use in its catalog & literature, field photographs of its products which may have been modified by the owners, products furnished by Kinglink may not necessarily be as illustrated therein. Also continuous design progress makes it necessary that specifications be subject to change without notice. All sales of the products of Kinglink are subject to the provisions of its standard warranty.

REV. 1 1/17

SHANGHAI KINGLINK INDUSTRY CO LTD

Address: South Shenjiang Road, Pudong district, Shanghai China

Tel: +86-21-68170058 +86-15601968455

Email: info@kinglink-china.com

